

CHELSEA® 238D SERIES

Pneumatic PowerShift PTO for Detroit® DT12® Transmissions

Parker Chelsea is eager to officially introduce the 238D Series PTO for the Detroit® Diesel DT12®, C & D version transmissions. The 238D Series is the first PowerShift PTO approved for this transmission.

This 8-bolt, PowerShift PTO offers up to 250 lb-ft [339 N-m] of torque and shift-on-the-fly capabilities, allowing the operator to engage the PTO at low engine RPM without stopping the vehicle. The 238D is ideal for water trucks, fuel delivery, and low-speed rolling applications.

The DT12® transmission's design is to maximize efficiency, and Parker Chelsea engineered the 238D Series PTO to complement the goal of maximum efficiency and versatility. You expect durability, reliability, and unmatched toughness from your Work Truck; don't settle for anything less from your PTO.

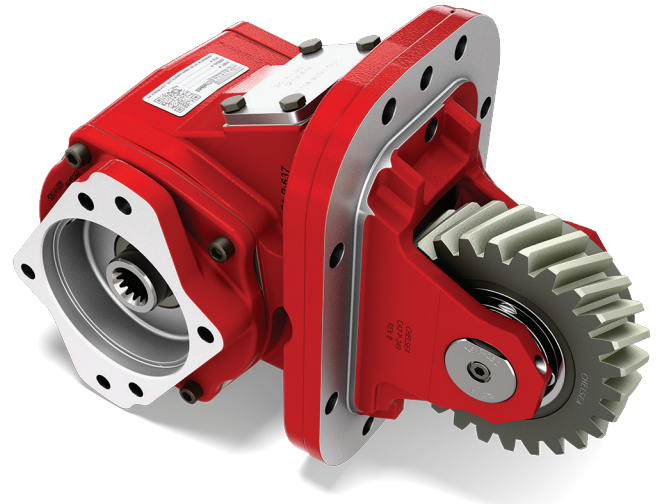

238D Series

Applications:

- LP Gas Trucks
- Water Trucks
- Dump Trucks
- Bulk Haul Trucks
- Fuel and Oil Trucks

Product Features and Benefits:

- Two Output Speed Ratios – Wider coverage for your applications.
- Output Options – Direct mount and driveline options available.
- Up to 250 lb-ft [339 N-m] of Torque – Allows coverage for most applications.
- Proven – Parker Chelsea Durability.
- Inspection Cover – Set backlash quickly and accurately.
- Slip Fit Idler Pin – Ease of Servicing.



238D Series Power Take-Off – Daimler/Detroit

Model Number Designator & Specifications

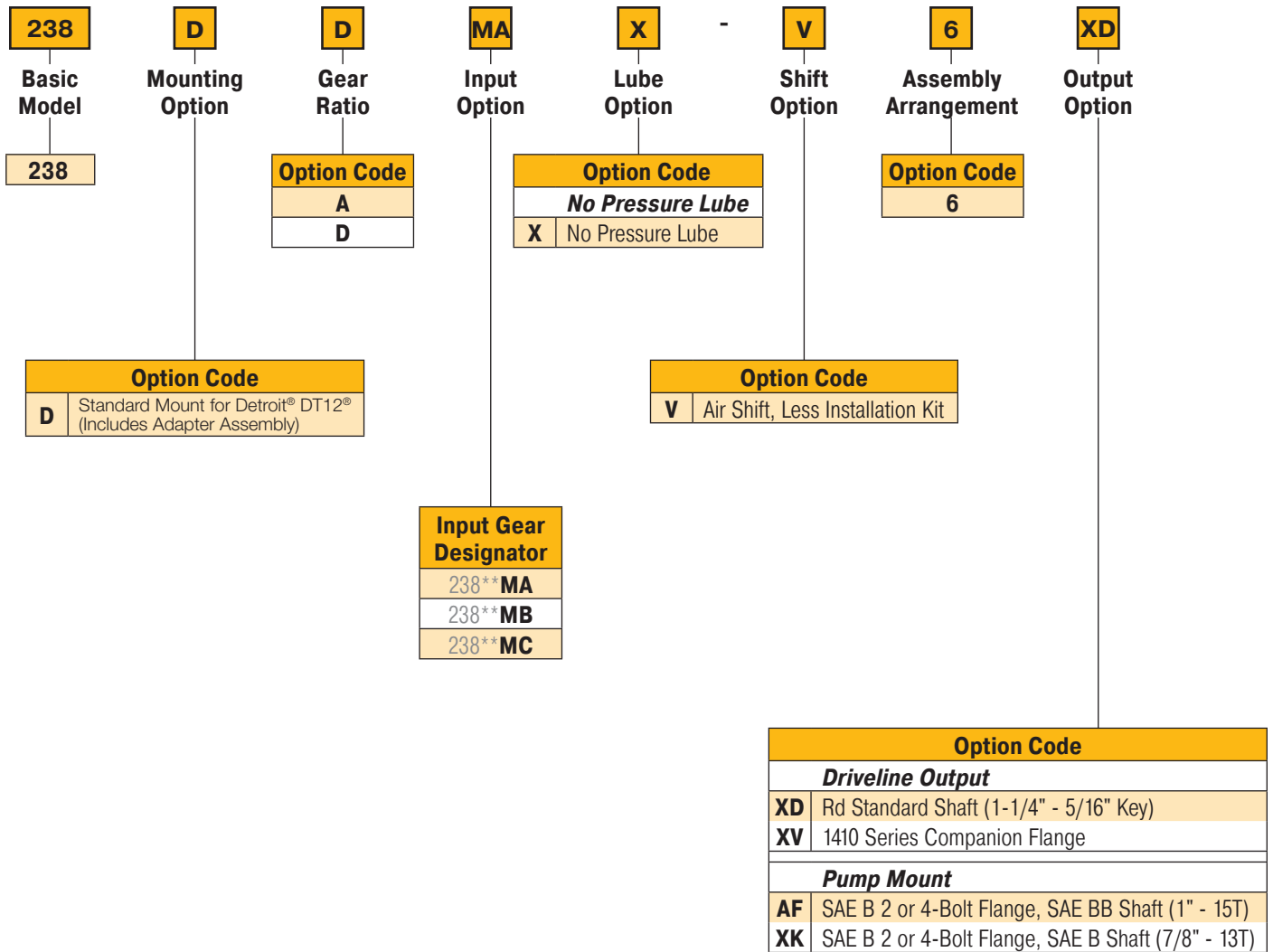

Specifications Chart	Approximate Weight: 66 lbs. [30 kg]	
	238D*A	238D*D
Intermittent Torque Rating lb-ft [N-m]	250 [339]	250 [339]
HP Rating for Intermittent Service		
At 500 RPM of Output Shaft HP [kW]	24 [18]	24 [18]
At 1000 RPM of Output Shaft HP [kW]	48 [36]	48 [36]

238D Series Power Take-Off – Daimler/Detroit

Dimensions – For PTO output information see application catalog

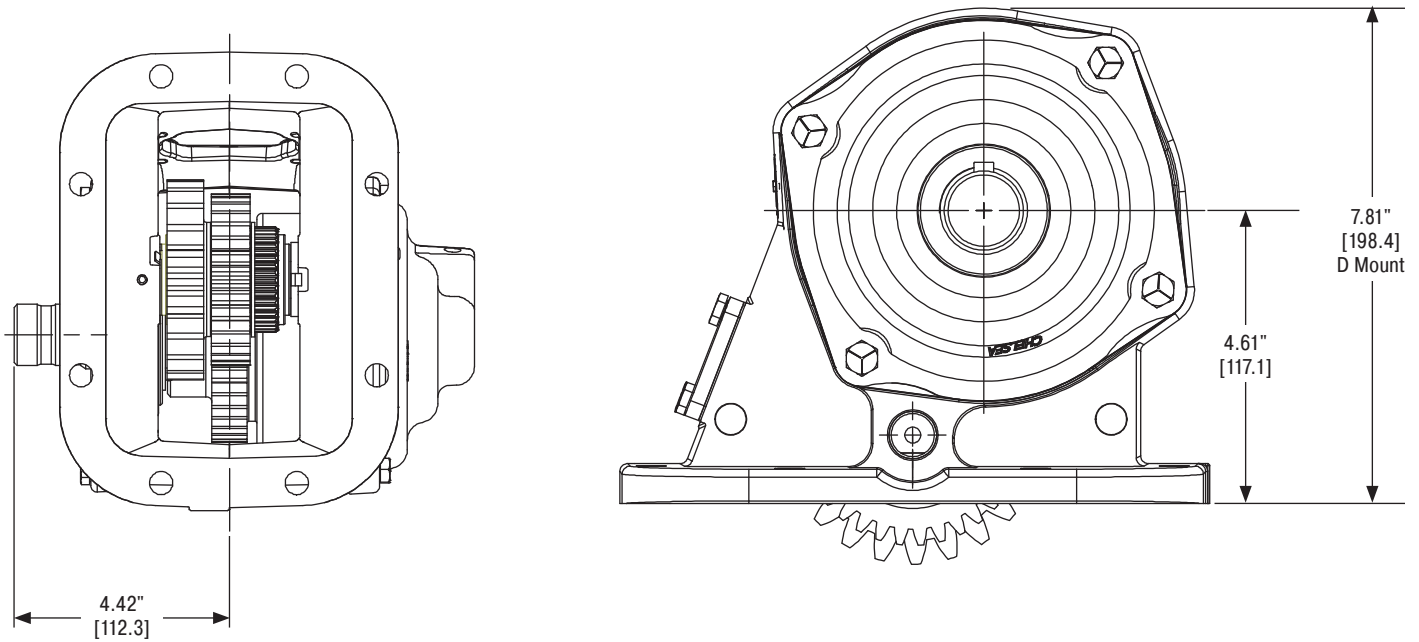

(Available in 6 Arrangement Only)

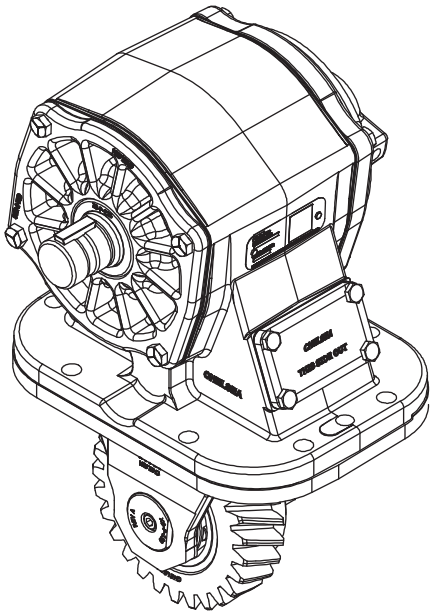

Parker Hannifin Corporation
Chelsea Products Division
8225 Hacks Cross Road
Olive Branch, MS 38654 USA
phone 1-888-PH4-TRUK (1-888-744-8785)
chd_support@support.parker.com
www.parker.com/chelsea

HY25-0216-B1/US November 2025

© 2025 Parker Hannifin Corporation

